

FOR MAINS VOLTAGE
400 V

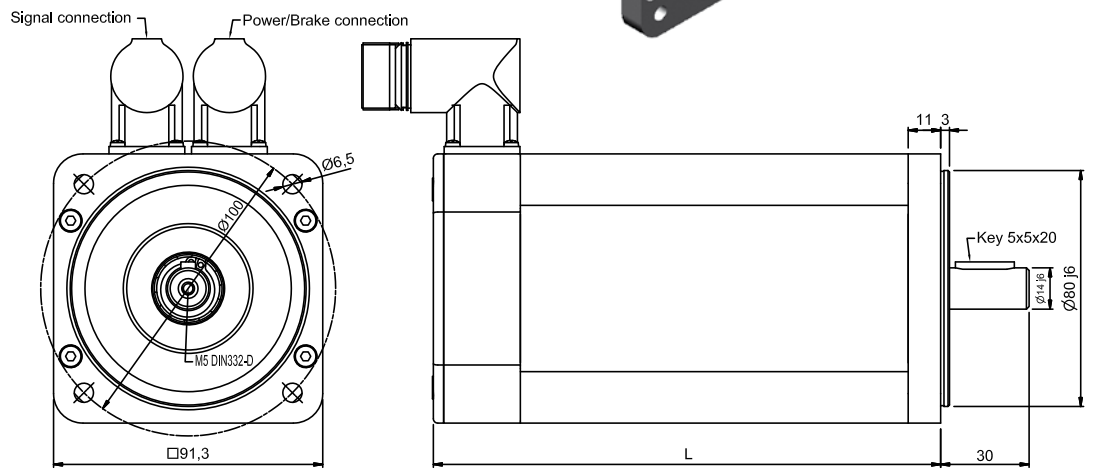
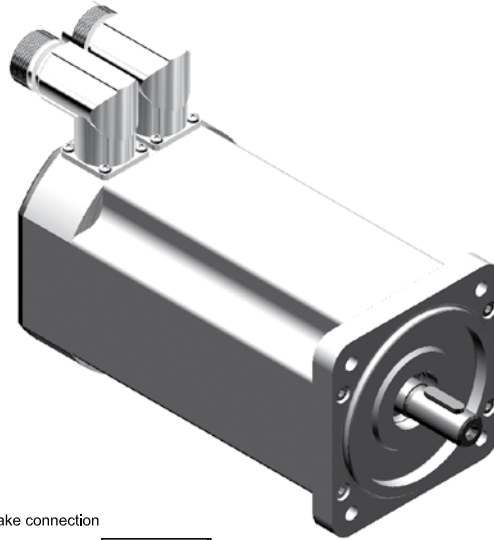

MECHANICAL DATA

| Type | Torque Nm | Length with RESOLVER (L) | | Maximum Length with ENCODER (L) | | Weight Kg | |
|---------|--------------|--------------------------|------------|---------------------------------|------------|---------------|------------|
| | | Without brake | With brake | Without brake | With brake | Without brake | With brake |
| B56.E3Q | 1.35 | 122 | 157 | 137 | 172 | 3.5 | 4.1 |
| B56.F6Q | 2.6 | 145 | 180 | 159 | 194 | 4.4 | 5.0 |
| B56.G5Q | 3.5 | 160 | 195 | 174 | 209 | 5.0 | 5.6 |
| B56.H5Q | 4.5 | 180 | 215 | 194 | 229 | 5.8 | 6.4 |

BRAKE DATA

| Brake data | Symbol | Data | Unit |
|---------------------------|--------|------|-------------------|
| Holding torque 20°C | Mbr | 3.2 | Nm |
| Voltage | Ubr | 24 | Vdc +/- 10% |
| Resistance | Rbr | 53.2 | Ohm |
| Electrical Power | Pbr | 10.8 | W |
| Current | Ibr | 0.45 | Adc |
| Additional* Rotor Inertia | Jbr | 0.38 | kgcm ² |
| Opening (release) time | to max | 60 | ms |
| Closing (fall in) time | tc max | 10 | ms |
| Additional* Motor weight | mbr | 0.6 | kg |

* Additional values are related to the motor data when the brake is mounted on the motor of the respective size, these values differ from the brake data in unmounted condition!

TYPE B56Q - 8 POLES

FOR MAINS VOLTAGE 400 V

| Type | Stall torque ($\Delta t=105^{\circ}\text{C}$) | Rated speed | Rated power | Rated torque ($\Delta t=105^{\circ}\text{C}$) | Peak torque | Maximum speed | Moment of inertia | Peak torque acceleration | Thermal time constant | Thermal protection threshold | Voltage constant | Torque constant | Resistance phase to phase (20°C) | Inductance phase to phase | B.E.M.F. at rated speed | Stall current | Rated current |
|---|--|-------------|-------------|--|----------------|------------------|-------------------------|--------------------------|-----------------------|---|------------------|-----------------|---|---------------------------|-------------------------|---------------|---------------|
| | M_o Nm | n 1/min | P_n kW | M_n Nm | M_{pk} Nm | n_{max} rpm | J 10^{-4} Kg m^2 | a_{pk} rad/sec 2 | T_{th} min | ϑ_{max} $^{\circ}\text{C}$ | k_e Vs | k_t Nm/A | R_w Ω | L_w mH | E_n Vrms | I_o Arms | I_n Arms |
| 3000 min$^{-1}$ - Self cooled | | | | | | | | | | | | | | | | | |
| B56.E3Q | 1.35 | 3000 | 0.4 | 1.3 | 5 | 9000 | 0.47 | 106383 | 31 | 140 | 0.94 | 1.63 | 37.4 | 137 | 296 | 0.8 | 0.8 |
| B56.F6Q | 2.6 | 3000 | 0.8 | 2.5 | 10 | 9000 | 0.88 | 113636 | 34 | 140 | 0.94 | 1.63 | 15.9 | 73.7 | 296 | 1.6 | 1.5 |
| B56.G5Q | 3.5 | 3000 | 1.0 | 3.1 | 14 | 9000 | 1.09 | 128440 | 36 | 140 | 0.94 | 1.63 | 10.7 | 54.7 | 296 | 2.1 | 1.9 |
| B56.H5Q | 4.5 | 3000 | 1.2 | 3.9 | 18 | 9000 | 1.40 | 128571 | 39 | 140 | 0.94 | 1.63 | 8.0 | 43.7 | 296 | 2.8 | 2.4 |
| 6000 min$^{-1}$ - Self cooled | | | | | | | | | | | | | | | | | |
| B56.E3Q | 1.35 | 6000 | 0.6 | 1.0 | 5 | 9000 | 0.47 | 106383 | 31 | 140 | 0.47 | 0.81 | 9.4 | 33.8 | 296 | 1.7 | 1.2 |
| B56.F6Q | 2.6 | 6000 | 1.1 | 1.7 | 10 | 9000 | 0.88 | 113636 | 34 | 140 | 0.47 | 0.81 | 4.0 | 18.2 | 296 | 3.2 | 2.1 |
| B56.G5Q | 3.5 | 6000 | 1.3 | 2.0 | 14 | 9000 | 1.09 | 128440 | 36 | 140 | 0.47 | 0.81 | 2.7 | 13.5 | 296 | 4.3 | 2.5 |
| B56.H5Q | 4.5 | 6000 | 1.4 | 2.3 | 18 | 9000 | 1.40 | 128571 | 39 | 140 | 0.47 | 0.81 | 2.0 | 10.8 | 296 | 5.6 | 2.8 |