

VFX70m Electronic Programmable Display

Programmed with Eaton Pro-FX™ Control Software

32-bit Processor, 7" WVQA Sunlight Viewable Display

The high performance VFX70m display is designed to provide an operator interface for on and off-highway mobile applications. This HMI features a powerful processor, bright sunlight viewable optically bonded LCD assembly, configurable CAN channels and flexible IO to meet the needs of a variety of demanding applications.



Technical Data

Functional Specification - Physical & Environmental

Dimensions	10.27 x 5.67" x 2.512"
Weight	.96 kg
Case Material	Polycarbonate back case
Storage Temperature Range	-40°C to +85°C
Operating Temperature Range	-40°C to +85°C
Heater	Standard
IP Rating - Front	IP66, IP67
IP Rating - Back	IP66, IP67

Power Supply

Supply Voltage	6-36 VDC
Peak Supply Voltage	36 VDC
Max Power Consumption	10 W
Max Power Consumption with Heater Option	22 W
Max Sleep Current	400 mA
Ignition Pin (K15)	Ignition pin will put the unit in 'sleep' mode when it is powered off.



Powering Business Worldwide

Technical Data

CPU

CPU Type	Freescall i.MX357
Frequency	532 MHz
Bit Width	32 bits
Operating System	Linux

Memory

RAM	128 MB DDR2
Data Memory (RAM retain)	1 MB
Flash (ROM program & data combined)	2 GB

Standards

Vibration	7.86 G RMS (5-2000 Hz) SAE J1455 Section 4.9.4.1
Shock	50g - SAE J1455 Section 4.10.4
Radiated Immunity	SAE J1113-21 (150 V/m), SAE J1113-26 (15 kV/m), EN61000-4-3 (10 V/m)
Radiated Emission	SAE J1113-41 (Class 4), CISPR 11 Class B/EN60945 Hybrid
Conducted Immunity	SAE J1113-2 (3.0 Vp-p), SAE J1113-4 (200 mA), SAE J1113-11 (Level 4), SAE J1113-12 (Level 4), EN61000-4-4, EN61000-4-5, EN60945 Sec 10.3 (3 V/10V RMS)

Certifications

CE Mark

Graphical Interface

Display Type	Bonded, color transmissive TFT LCD
LCD Size	7"
Resolution	800 x 480, WQVGA
Color Format Supported	16-bit color
Aspect Ratio	16:9
Orientation	Landscape
Display Back Light	LED, >1000 cd/m ² (50,000 hr lifetime)
Sunlight Viewability	Direct sunlight

Touch Interface (Optional feature: not included on all models)

Touch screen technology	Projected capacitive
--------------------------------	----------------------

Video Interface (Optional feature: not included on all models)

Video Type	3 NTSC/PAL
-------------------	------------

Boot-up

Boot-up Screen	Customizable
Boot (first powered-on):	TYP. ~ 9 sec. to logo, 17 sec. to first screen
Wake (ignition switched):	TYP. ~1 sec.

Technical Data

Communications

CAN Interface 1

CAN Specification	2.0A, 2.0B
Baud Rates	Configurable 125 kb/s, 250 kb/s, 500 kb/s, 1 Mb/s
Protocols	J1939 and CANopen master

CAN Interface 2

CAN Specification	2.0A, 2.0B
Baud Rates	Configurable 125 kb/s, 250 kb/s, 500 kb/s, 1 Mb/s
Protocols	J1939 and CANopen master

USB Interface

USB Specification	USB 2.0
Baud Rate	Supports USB full speed at 6 Mbit/s

Note: USB interface is not protected against battery level faults.

Real Time Clock

Estimated Battery Life	Minimum 9.5 yr (display never powered)
Rechargeable	No, Lithium (non-replaceable)

Keypads

Number of Buttons	14
Button Style	Tactile feedback
Button Backlight	Yes

Digital Inputs x 5

Type	High Side in
Input Impedance	10 kOhm
Scan Rate	10 Hz (100 ms)
Switch-on Level	4.01 V
Switch-off Level	1.04 V
Short Circuit Protection	28 V or Ground

Analog Inputs x 3 (Software configurable)

Resolution	10 bits
Accuracy	+/- 1% FS
Measuring Ranges	Digital, 0-5 V, 4-20 mA, Resistive
Scan Rate	10 Hz (100 ms)

Digital Input

Type	High Side in
Input Impedance	10 kOhm
Switch-on Level	4.01 V
Switch-off Level	1.04 V

Voltage Input - 0 - 5V

Input Impedance	100 Ohm
------------------------	---------

Current Input - 0 - 24 mA

Input Impedance	200 Ohm
------------------------	---------

Technical Data

Resistive (0-5V)

Pull-up Resistance	400 Ohm
---------------------------	---------

Frequency Input

Type	3.6 VAC – 120 VAC
Input Impedance	14.02 kOhm
Input Frequency	2 Hz - 10 kHz
Switch-on Level	2.10 V
Switch-off Level	1.17 V

Outputs

Digital Output – 500 mA

Type	Low Side
Amperage	500 mA Max.
Protection	Short circuit protection

Frequency Output

Type	Square wave
Duty Cycle	50%, non-adjustable
Frequency Range	2 Hz - 3 kHz

Connections

Connector – 2 x 23 pin Ampseal

Manufacturer	AMP
Model	770680-1 (Black), 770680-4 (Gray)
Contact Surface	Nickel plated

Tooling

Manufacturer	AMP
Hand Tool Part Number	58529-1
Die Part Number	58529-2

Block Diagram

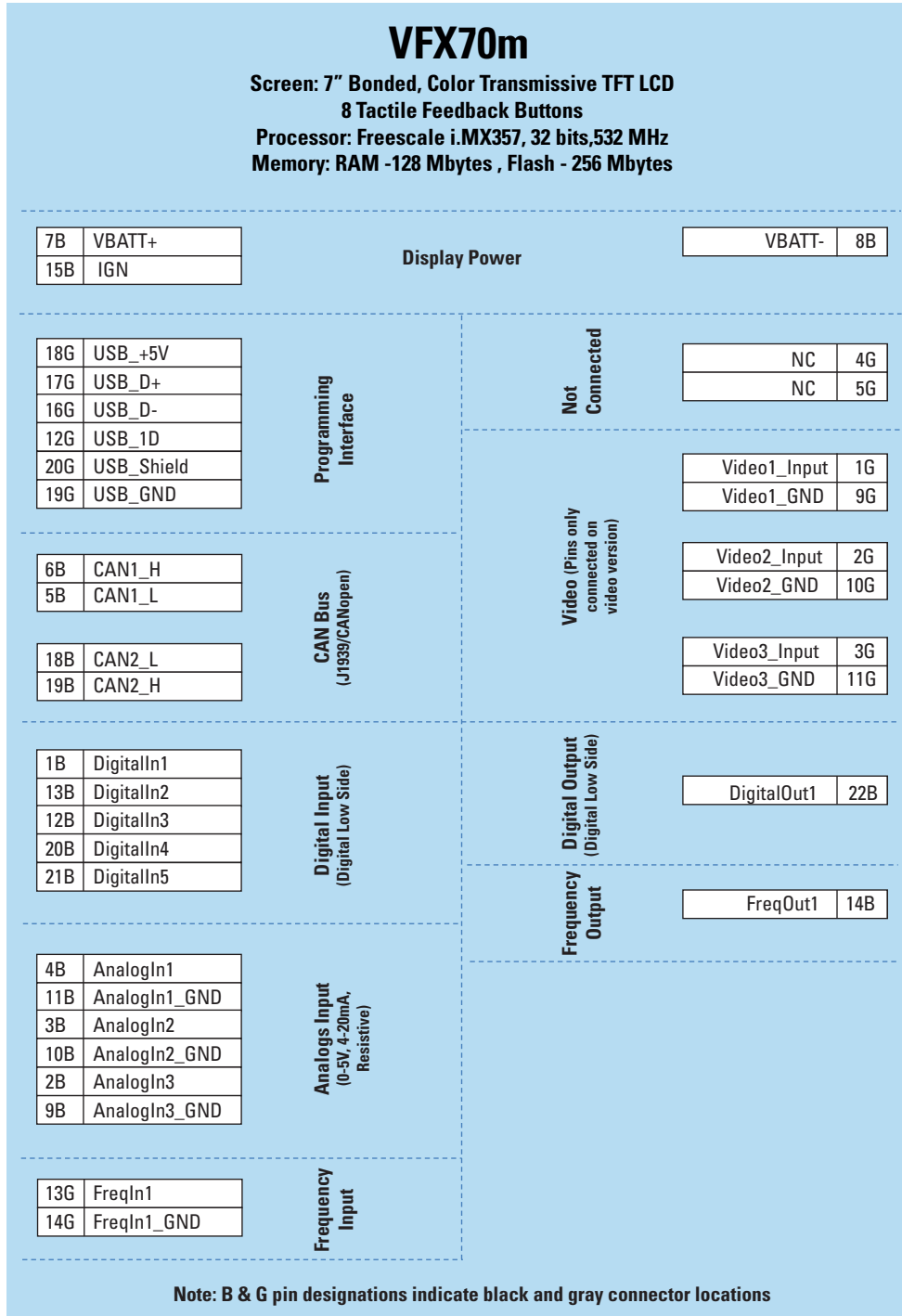

Connector Pins

Connector 1

Type	Deutsch	AMP770680-1 (Black)
Pin		
1	Digital Input 1	
2	Analog Input 3	
3	Analog Input 2	
4	Analog Input 1	
5	CAN1 L	
6	CAN1 H	
7	Battery	
8	Ground	
9	Analog Input 3 Ground	
10	Analog Input 2 Ground	
11	Analog Input 1 Ground	
12	Digital Input 3	
13	Digital Input 2	
14	Analog gauge output 1	
15	Ignition In	
16	Not Connected	
17	Not Connected	
18	CAN2 L	
19	CAN2 H	
20	Digital Input 4	
21	Digital Input 5	
22	Digital Output	
23	Not Connected	

Connector 2

Type	Deutsch	AMP770680-4 (Grey)
Pin		
1	Video Input 1 (*Not Connected)	
2	Video Input 2 (*Not Connected)	
3	Video Input 3 (*Not Connected)	
4	Not Connected	
5	Not Connected	
6	Not Connected	
7	Not Connected	
8	Not Connected	
9	Video Input 1 Ground (*Not Connected)	
10	Video Input 2 Ground (*Not Connected)	
11	Video Input 3 Ground (*Not Connected)	
12	USB ID	
13	Frequency Input	
14	Frequency Return	
15	Not Connected	
16	USB D-	
17	USB D+	
18	USB 5V	
19	USB Ground	
20	USB Shield	
21	Not Connected	
22	Not Connected	
23	Not Connected	

Mounting

Configurations - Front, Back and Gimble

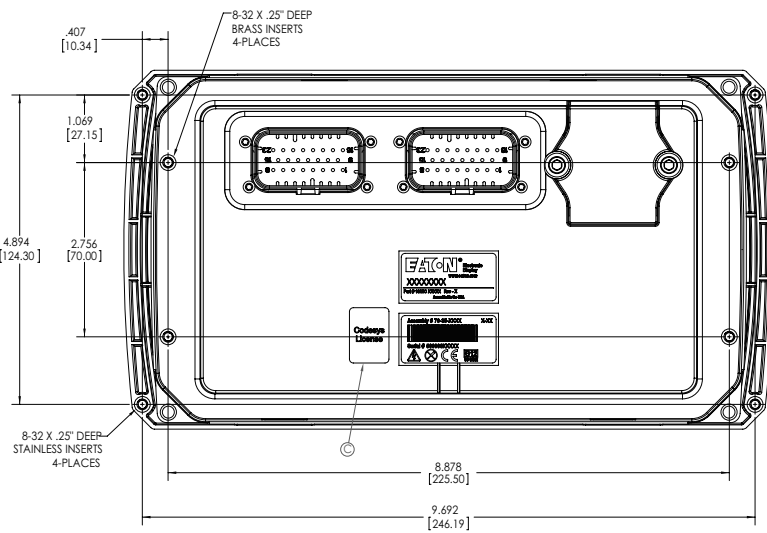
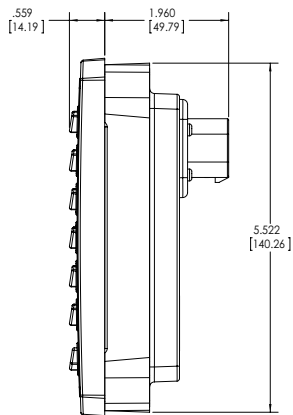
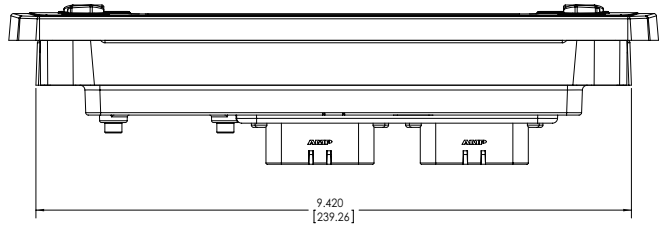
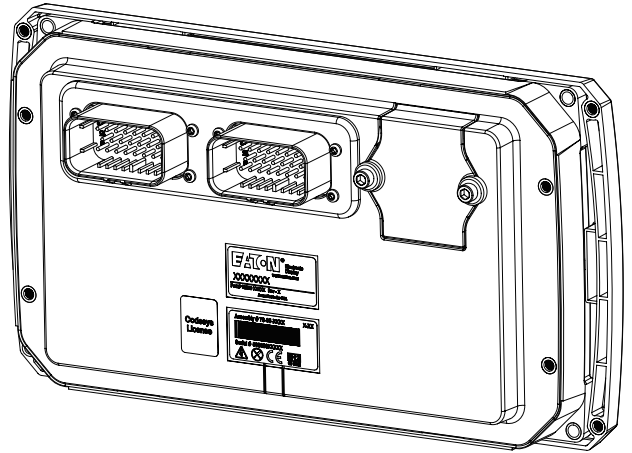
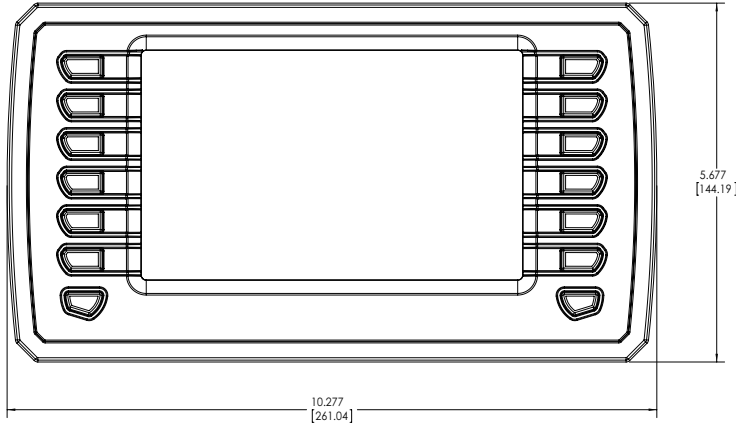
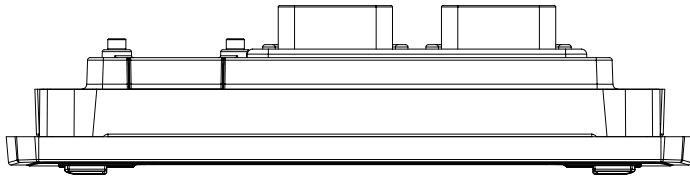

Eaton
Hydraulics Group USA
14615 Lone Oak Road
Eden Prairie, MN 55344
USA
Tel: 952-937-9800
Fax: 952-294-7722
www.eaton.com/hydraulics

Eaton
Hydraulics Group Europe
Route de la Longeraie 7
1110 Morges
Switzerland
Tel: +41 (0) 21 811 4600
Fax: +41 (0) 21 811 4601

Eaton
Hydraulics Group Asia Pacific
Eaton Building
No.7 Lane 280 Linhong Road
Changning District,
Shanghai 200335
China
Tel: (+86 21) 5200 0099
Fax: (+86 21) 2230 7240



Powering Business Worldwide

© 2014 Eaton
All Rights Reserved
Printed in USA
Document No. E-ELDI-TT002-E1
July 2014