

VFX41m Electronic Programmable Display

Programmed with Eaton Pro-FX™ Control Software

32-bit Processor, 4.3" WVQA Sunlight Viewable Display

The high performance VFX41m display is designed to provide an operator interface for on and off-highway mobile applications. This HMI can accept up to 2 video inputs, features a powerful processor, bright sunlight viewable optically bonded LCD assembly, configurable CAN channels, and flexible I/O to meet the needs of a variety of demanding applications.

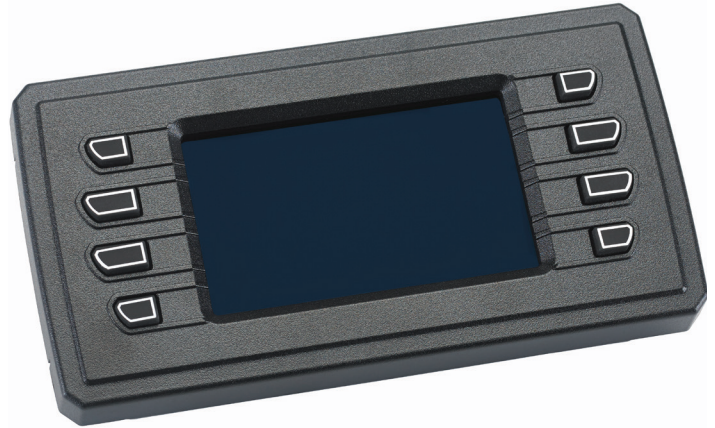

Technical Data

Dimensions	7.69" x 4.00" x 2.34"
Weight	.44 kg
Case Material	ABS/Polycarbonate blend cases
Storage Temperature Range	-40°C to +85°C
Operating Temperature Range	-40°C to +85°C
IP Rating - Front	IP66, IP67
IP Rating - Back	IP66, IP67

Power Supply

Supply Voltage	6-32 VDC
Peak Supply Voltage	32 VDC
Max Power Consumption	10 W
Max Sleep Current	400 mA
Ignition Pin (K15)	Ignition pin will put the unit in 'sleep' mode when it is powered off.



Powering Business Worldwide

Technical Data

CPU

CPU Type	Freescale i.MX357
Frequency	532 MHz
Bit Width	32 bits
Operating System	Linux

Memory

RAM	128 MB DDR2
Data Memory (RAM retain)	1 MB
Flash (ROM program & data combined)	256 MB

Standards

Vibration	7.86 G RMS (5-2000 Hz) SAE J1455 Section 4.9.4.1
Shock	50g - SAE J1455 Section 4.10.4
Radiated Immunity	SAE J1113-21 (150 V/m), SAE J1113-26 (15 kV/m), EN61000-4-3 (10 V/m)
Radiated Emission	SAE J1113-41 (Class 4), EN50121-3-2, EN60945, EN61000-6-3
Conducted Immunity	SAE J1113-2 (3.0 V _{p-p}), SAE J1113-4 (200 mA), SAE J1113-11 (Level 4), SAE J1113-12 (Level 4), EN61000-4-4, EN61000-4-5, EN60945 Sec 10.3 (3 V/10 V RMS), EN50121-3-2 (10 V RMS)

Certifications

CE Mark

Graphical Interface

Display Type	Bonded, color transmissive TFT LCD;
LCD Size	4.3"
Resolution	480 x 272, WQVGA
Color Format Supported	16-bit color
Aspect Ratio	16:9
Orientation	Landscape
Display Backlight	LED, 500-650 cd/m ² (30,000 hr lifetime)
Sunlight Viewability	Direct sunlight

Video Interface (Optional feature- not included on all models)

Video Type	2 NTSC/PAL
-------------------	------------

Boot-up

Boot-up Screen	Customizable
Boot (first powered-on):	TYP. ~ 9 sec. to logo, 17 sec. to first screen
Wake (ignition switched):	TYP. ~1 sec.

Technical Data

Communications

CAN Interface 1

CAN Specification	2.0A, 2.0B
Baud Rates	Configurable 125 kb/s, 250 kb/s, 500 kb/s, 1 Mb/s
Protocols	J1939 and CANopen master

CAN Interface 2

CAN Specification	2.0A, 2.0B
Baud Rates	Configurable 125 kb/s, 250 kb/s, 500 kb/s, 1 Mb/s
Protocols	J1939 and CANopen master

USB Interface

USB Specification	USB 2.0
Baud Rate	Supports USB full speed at 6 Mbit/s

Note: USB interface is not protected against battery level faults.

Real Time Clock

Estimated Battery Life	Minimum 300 day time/date retention between charges
Rechargeable	Yes, Li-Ion (non-replaceable)

Keypads

Number of Buttons	8
Button Style	Tactile feedback
Button Backlight	Yes

Input

Resolution	10 bits
Accuracy	+/- 1% FS
Measuring Ranges	Digital, 0-5 V, 4-20 mA, Resistive
Scan Rate	10 Hz (100 ms)

Digital Input

Type	High Side in
Input Impedance	100 kOhm
Switch-on Level	4.01 V
Switch-off Level	1.04 V

Voltage Input - 0 - 5V

Input Impedance	10 kOhm
------------------------	---------

Current Input - 0 - 24 mA

Input Impedance	200 Ohm
------------------------	---------

Resistive (0-5V)

Pull-up Resistance	400 Ohm
---------------------------	---------

Technical Data

Outputs

Digital Output – 500 mA

Type	Low Side
Amperage	500 mA Max
Diagnostics	Open/Short circuit protection

Connections

Connector – 4 x 6 pin

Manufacturer	Deutsch
Model	DT04-6P
Contact Surface	Nickel plated

Block Diagram

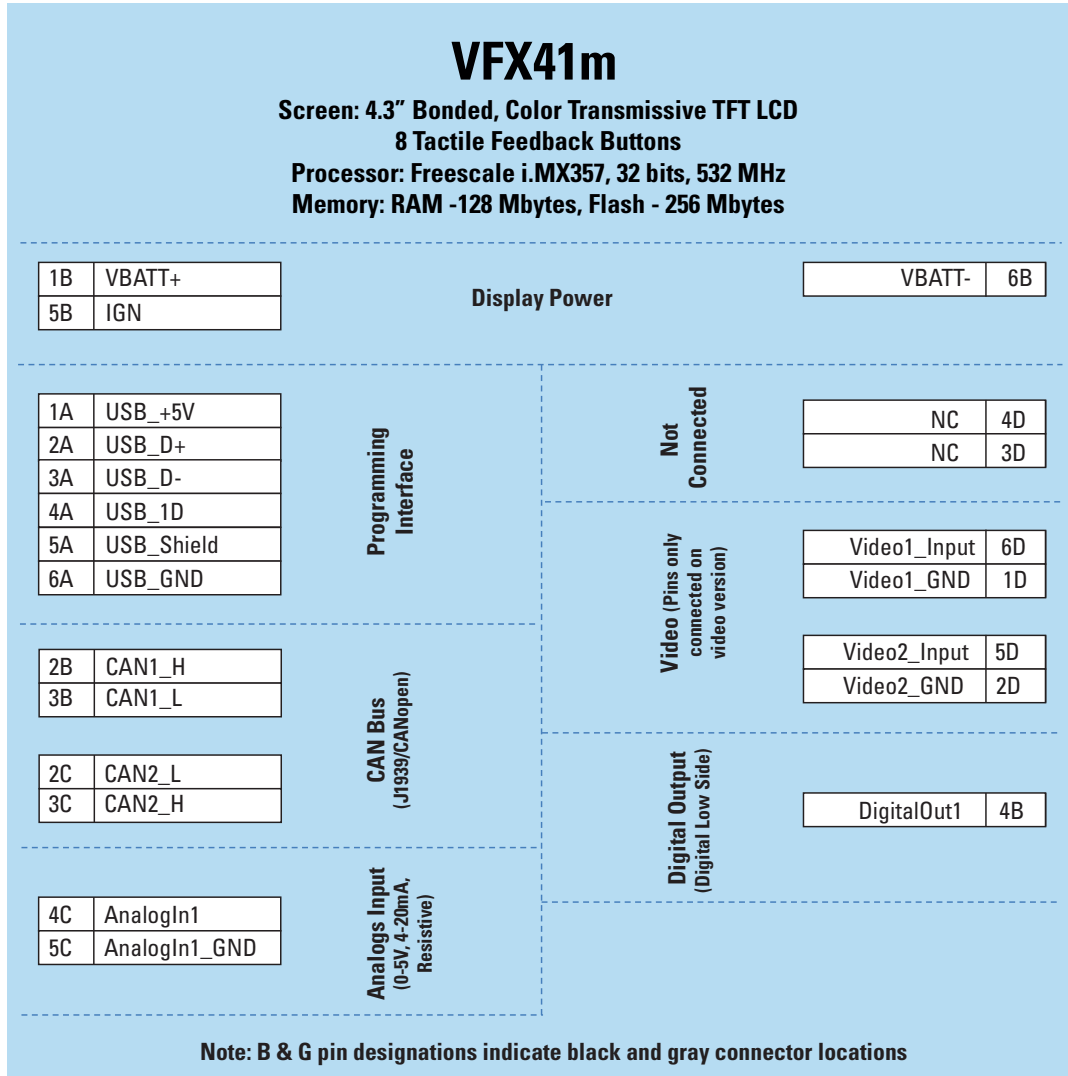

Connector Pins

Plug A

Type	Deutsch
Pin	Function
1	USB 5V
2	USB D+
3	USB D-
4	USB 1D
5	USB Shield
6	USB Ground

Plug B

Type	Deutsch
Pin	Function
1	Battery
2	CAN1 H
3	CAN1 L
4	Open-Drain Battery Output
5	Ignition Input
6	Ground

Plug C

Type	Deutsch
Pin	Function
1	Not Connected
2	CAN2 H
3	CAN2 L
4	Analog Input Ground
5	Analog Input
6	Not Connected

Plug D

Type	Deutsch
Pin	Function
1	Video Ground 1 (*Not Connected)
2	Video Ground 2 (*Not Connected)
3	Not Connected
4	Not Connected
5	Video Input 2 (*Not Connected)
6	Video Input 1 (*Not Connected)

Mounting

Configurations - Front, Back and Gimble

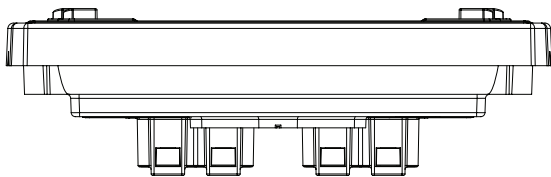
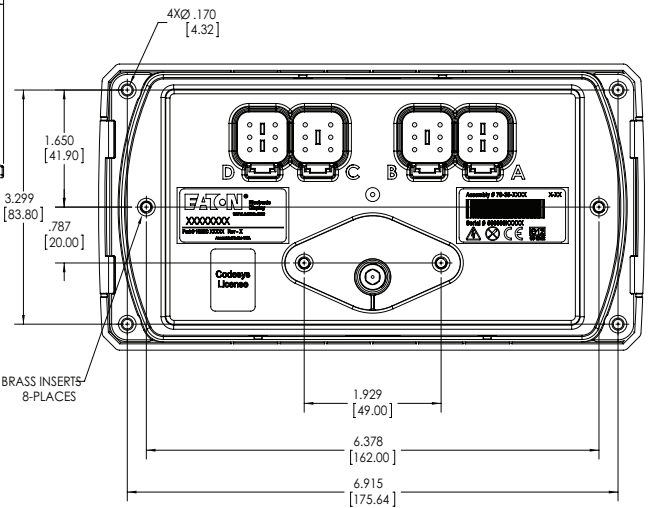
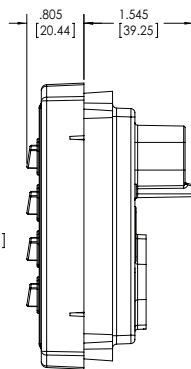
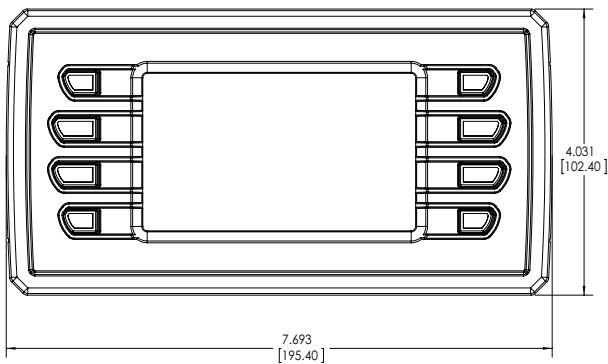
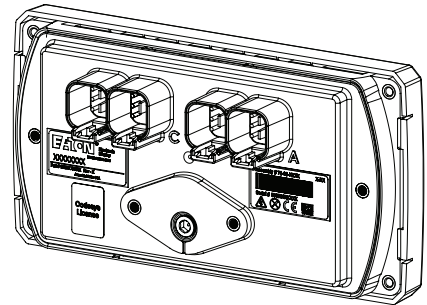
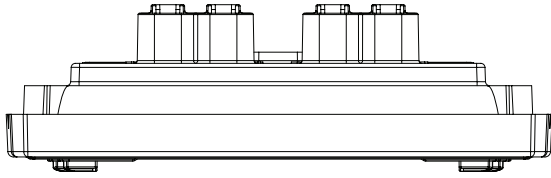

8-32 X .25" DEEP BRASS INSERTS-
8-PLACES

Eaton
Hydraulics Group USA
14615 Lone Oak Road
Eden Prairie, MN 55344
USA
Tel: 952-937-9800
Fax: 952-294-7722
www.eaton.com/hydraulics

Eaton
Hydraulics Group Europe
Route de la Longeraie 7
1110 Morges
Switzerland
Tel: +41 (0) 21 811 4600
Fax: +41 (0) 21 811 4601

Eaton
Hydraulics Group Asia Pacific
Eaton Building
No.7 Lane 280 Linhong Road
Changning District,
Shanghai 200335
China
Tel: (+86 21) 5200 0099
Fax: (+86 21) 2230 7240